

INSTALLATION MANUAL

CSD-10

MODELS

1200006-005 THROUGH -010

**CSD-10 SELCAL
INSTALLATION AND
OPERATION MANUAL**

Avtech Part Numbers 1200006-005, -006, -007, -008, -009, -010

**MANUAL PART NUMBER
0200008-005**

PROPRIETARY RIGHTS NOTICE

THIS DATA IS PROPRIETARY TO AVTECH CORP. DISCLOSURE,
REPRODUCTION, OR USE OF THIS DATA FOR ANY PURPOSE IS
NOT AUTHORIZED WITHOUT WRITTEN PERMISSION FROM
AVTECH CORP.

**Avtech Corporation
A DAH Company
3400 Wallingford Avenue North
Seattle, Washington USA 98103-9095
Phone 206-695-8000
Fax 206-695-8011**

CHANGE RECORD

REV	PAGE	DESCRIPTION	APPROVED
1	All	Cloned from Coltech document 0200008-005 Rev D. All textual references to Coltech and formatting has been changed to Avtech where possible. This component maintenance manual may contain references to Coltech drawings and document numbers. REF DCR D010009	

SERVICE BULLETIN RECORD

<u>Service Bulletin</u>	<u>Date Issued</u>	<u>Model Effected</u>	<u>Subject</u>
-----------------------------	------------------------	---------------------------	----------------

TABLE OF CONTENTS

<u>TITLE</u>	<u>PAGE</u>
DESCRIPTION	1
OPERATION	2
SPECIFICATIONS	3
INSTALLATION	6
INSTALLATION TESTING	9
EQUIPMENT AND ACCESSORY PART NUMBERS	9
LAMP AND LEGEND CHANGING	10

LIST OF FIGURES

<u>FIGURE</u>	<u>TITLE</u>	<u>PAGE</u>
Figure 1	- CSD-10-5 thru -8 Wiring Diagram	11
Figure 2	- CSD-10-9 and -10 Wiring Diagram	12
Figure 3	- Outline Drawing	13
Figure 4	- Code Programming	14
Figure 5	- 20 dB Attenuator	15

DESCRIPTION

The CSD-10 SELCAL DECODER is a dzus rail mounted, two channel, 16 tone decoder for the ICAO and ARINC standard SELCAL system, as defined in RTCA paper DO-93. It has resistively combined inputs for up to five radio sources to drive its two decoder channels. It is connected to any communication radio receivers (typically the VHF and HF receivers) and monitors their audio outputs for the SELCAL tone codes. Upon receiving the code for which it is programmed it will cause an annunciator light to flash and a audio signal to be generated by its internal speaker to alert the crew that a call has been received.

This manual covers six different versions of CSD-10, all of which are basically identical. The units covered by this manual are model numbers CSD-10-5, CSD-10-6, CSD-10-7, CSD-10-8, CSD-10-9, and CSD-10-10, Avtech/Coltech part numbers 1200006-005, -006, -007, -008, -009 and -010, respectively. The only difference between the CSD-10-5 and the CSD-10-6 is the bezel color, with the -5 being black and the -6 being grey. The CSD-10-7 and -8 are the same as the -5 and -6 versions, only the internal ringer has been deleted and the bezel does not have the openings for the ringer output. The CSD-10-9 and -10 are the same as the CSD-10-5 and -6, except they have a backlit bezel and decoder channel 1 only has one radio input. Within this document, reference to the CSD-10 applies equally to any of these six dash numbers and any reference to audio annunciation should be ignored when considering the CSD-10-7 or -8.

Certified to TSO C59 and designed to meet or exceed the performance requirements of ARINC Characteristics 596 and 714, the CSD-10 uses proven aircraft techniques and materials and is digitally based and crystal controlled using a microprocessor, digital filters and signal processing, and digital frequency generation for its decoding functions. The entire unit is housed in an anodized aluminum case with the front bezel made of machined aluminum and anodized and painted for protection and appearance. The materials used within the unit are of the high quality associated with air transport equipment and consideration has been given to the safety and reliability requirements of air transport operations.

The annunciator light on the unit has replaceable filters to allow easy field change of the legends of the light, and has two bulbs for each legend to assure that annunciation will always be available. The legends are field changable and are available in a number of versions. The light is removable from the front without tools to allow field replacement of the light bulbs.

By connecting pins in the rear connector of the unit, the individual code assigned to the aircraft is programmed for the unit to recognize. Outputs are provided to connect to aircraft systems for external annunciation of calls.

A Self-Test function is activated by pressing the annunciator light and will cause the lights to flash and the audio annunciator to sound in verification that the internal circuits are functioning properly.

OPERATION

Pilot operation of the CSD-10 is limited to resetting it after a call and performing a self test.

Resetting the unit after a call is accomplished by pressing the annunciator lamp on the front panel or the optional external reset switch if installed.

Generating a SELF TEST is also done by pressing the annunciator lamp. As long as the lamp is held depressed it will be lighted and the aural signal will be generated. Testing of the lamp can also be accomplished by activating the aircraft master lamp test circuit if the aircraft is equipped with one and it is connected to the CSD-10.

If a selective call sequence is detected, the annunciator lamp segment for the associated receiver will flash and the audio signal will consist of a one second on, one second off sequence, continuing for two rings and sounding much like a conventional telephone ringing. The annunciation mode may be cancelled at any time by pressing the lamp. The ring sequence will be repeated every 30 seconds and the lamp will constantly flash until the unit is reset. If an external chime is connected to the NON-INTERRUPT line of the unit it will be rung at 30 second intervals also.

SPECIFICATIONS

Model Number:	CSD-10
Avtech Part Numbers:	1200006-005 (5 radio inputs, Black Bezel) 1200006-006 (5 radio inputs, Grey Bezel) 1200006-007 (5 radio inputs, Black Bezel, No Ringer) 1200006-008 (5 radio inputs, Grey Bezel, No Ringer) 1200006-009 (3 radio inputs, Black Bezel, Lighted) 1200006-010 (3 radio inputs, Grey Bezel, Lighted)
Certified to TSO:	C59
Conforms to RTCA Spec:	DO-93 as amended.
RTCA DO-160B Categories:	F1BA/PKS/XXXXXXXXZAZZZB
Software Certification:	Software has been tested and documented per the requirements of RTCA paper DO-178A for Level 3 software.
ARINC Characteristics:	Complies with the performance requirements of ARINC characteristic 714.
Number of Decoder Channels:	Two
Number of Radio Inputs:	1200006-005 thru -008: 3 Inputs to decoder channel 1 2 Inputs to decoder channel 2 1200006-009 thru -010: 1 Input to decoder channel 1 2 Inputs to decoder channel 2 Decoder channels with multiple inputs have the radio inputs resistively combined within the unit.
Size:	5.75" wide, 1.87" high, 4.80" deep behind mounting surface
Mounting:	Aircraft Dzus rail per Mil Specs MS25212 and MS25213
Weight:	1 pound 7 ounces
Operating Temperature:	-20 degrees centigrade to +70 degrees centigrade continuous.
DO-160B Vibration:	Categories PKS for non-vibration isolated mounting in Helicopters and Fixed Wing turbojet and propeller driven aircraft.

Operating Altitude:	Up to 55,000 feet, non-pressurized.
Input Voltage:	20 to 35 VDC, 27.5 VDC nominal. Voltage below 18 VDC will inhibit operation of annunciators and decoding.
Input Current:	60 ma nominal, 200 ma maximum
Mating Connector:	MS34761 18-32S per MIL-C-26482 series II or equivalent
Tone Inputs:	Three or five inputs, transformer coupled, resistively combined internally. Each input is nominally 10,000 ohms input impedance.
Input Tone Level:	0.1 VMS to 3.2 VMS
Tone Frequency Tolerance:	Normal operation with tones less than 0.3% off frequency.
Tone Rejection:	Greater than 36 dB rejection to tones more than +/- 3.5 percent off frequency.
Tone Amplitude Difference: (Twist)	Must be less than 10 dB.
Tone Duration:	750 milliseconds minimum, 1.25 seconds maximum
Tone to Noise Ratio:	-6 dB minimum.
Tones Decoded:	16 ARINC standard SELCAL tones, labeled A, B, C, D, E, F, G, H, J, K, L, M, P, Q, R, S.
Code Selection Method:	Jumper wires in the installation harness
ARINC Interfaces:	NON-INTERRUPT and INTERRUPT lines, turned on per ARINC 714 for chime and external annunciators. Maximum off voltage, 80 VDC. Maximum on current, 0.5 amps.
External Reset:	External switch, normally open. Closure to ground will reset annunciators or cause self-test as appropriate.
Audio Annunciator:	Miniature electromagnetic transducer. Output level greater than 95 DBA at 4" from front bezel.

Audio Signal:	Alternating 2000 Hz and 1600 Hz tone, combined to give a warble sound. Switched on and off at 1 Hz rate to simulate telephone like ringing for two rings. If not reset within 30 seconds, repeats ring sequence.
Annunciator Lamps:	Split lens with two 28 volt type 327 bulbs in each half. Bulbs replaceable without disassembly. These lamps may be replaced with a 5 volt equivalent by installation personnel if desired. Legends are available for VHF 1, VHF 2, VHF 3, HF 1, HF 2. Others are available upon request.
Annunciator Lamp Dimming:	AC or DC annunciator lamp power is provided on a separate input pin by the aircraft dimmer system or other power source.
Lamp Test:	Connected to ground side of lamps via isolation diodes. Any impedance to ground on this line will allow current to flow through the lamps. Grounding this line will cause the lamps to light for test purposes.
Panel Lamps:	The legend below the annunciator button is illuminated by incandescent 5v bulbs on the CSD-10-9 and -10 models. A hi and lo pin on the rear connector are dedicated to this lighting function.
Self Test:	Pressing annunciator lamp when not flashing verifies that the computer, transpond tone output, lamps, and audio annunciator are functional. Does not activate PTT lines.

INSTALLATION

The CSD-10 is intended for mounting in the pedestal of an aircraft or on its main or overhead panel, as selected by the installer. It should be mounted within reach of the crew and should be where it may be easily heard.

At installation it is necessary to connect various pins in the units connector to program the sequence necessary for a valid decode. This procedure is detailed in Note 1 for Figure 1 of this section.

The installation wiring drawing (Figure 1 or 2) shows connection pins for airline VHF communication transceivers which meet either ARINC characteristic 716 or 566. Other transceivers may be used, such as HF units, if the equivalent pins are utilized.

Audio for the CSD-10 input should be obtained from the SELCAL output of normal VHF and HF receivers. The audio level at the SELCAL output is normally within the range of the input levels accommodated by the CSD-10 and may be connected directly. If the CSD-10 is to be wired to the squelched audio as might be found at the input to the audio selector panel, the levels are generally greater than the maximum input rating of the CSD-10. In this case, a 10 to 1 voltage divider (20 dB of attenuation) should be used in the audio input to the decoder. Avtech provides an inline attenuator under the part number 1200009-000. This attenuator will reduce normal aircraft audio levels (100 mw into 600 ohms, equivalent to 7.7v RMS) to a level compatible with the CSD-10 (0.03 to 3.2v RMS).

The assignment of codes for SELCAL operation is coordinated by SELCAL Registrar, Aeronautical Radio, Inc., 2551 Riva Road, Annapolis, Maryland, 21401. Phone number is (410) 266-4142. Contact them if a code has not been assigned to the aircraft. They will require the following information:

Name of Applicant Company
Person to Contact
Aircraft Registration Number
Company Address
Intended world areas of operation
If your decoder is a 12 or 16 tone decoder.
(The CSD-10 is a 16 tone decoder)

There is no charge for a code assignment at this time. This code is assigned to the USER and does NOT transfer with the aircraft when it is sold.

NOTES FOR FIGURE 1 and FIGURE 2

NOTE 1: Decode Programming

Programming the CSD-10 to respond to a selective call is done by connecting the code selection pins to the CODE SELECT COMMON pin according to Figure 4. The SELCAL code is composed of four letters. For instance a code might be FJ-LQ. The order of the letters within a group of two is not critical, however it is customary to place them in alphabetical order. The code pins are labelled according to the tone they control. Those pins labelled LETTER 1-X set the first code letter, F in the example. LETTER 2-X sets the second code letter. LETTER 3-X and LETTER 4-X set the second code letter pair. Figure 4 has an example.

NOTE 2: Lamp Power In

The nominal 27.5 VDC aircraft power may be connected to the LAMP PWR IN line (Pin C) for full brightness at all times or this pin may be connected to the aircraft master dimmer bus. The lamp type is typically a type 327, with a rating of 28 volts and nominally 80 ma. Four lamps are used so adequate current capacity must be provided. An internal diode will half-wave rectify any AC lamp voltages and may give a less bright output than DC.

NOTE 3: External Reset

The EXTERNAL RESET line (Pin P) connects directly to the RESET/TEST switch of the CSD-10. A normally open switch connected to this pin will have exactly the same action on the CSD-10 as the front panel switch.

NOTE 4: Lamp Test Function

The LAMP TEST function (Pin L) requires a connection to ground to operate. It may be connected to aircraft master test circuits as desired since it is fully diode isolated within the unit.

NOTE 5: INTERRUPT and NON-INTERRUPT ARINC Outputs

The CH 1 INTERRUPT IN (Pin U), CH2 INTERRUPT IN (Pin e) and NON-INTERRUPT (Pin c) outputs are intended to drive an external chime or annunciator lamps mounted elsewhere in the cockpit. They are all open collector transistors which can withstand 80 volts when off and connect to power ground when on. They will carry 0.5 amps maximum when on. When on and sinking 0.5 amps, the voltage at the pin may be as high as 1 volt. The INTERRUPT lines are driven by the same logic which flashes the internal annunciator lamps and will be on and off in sync with the corresponding segment of the internal annunciator. The NON-INTERRUPT line will turn on as soon as either annunciator segment turns on and will stay on until reset. If the CSD-10 is not reset within 30 seconds, the NON-INTERRUPT line will turn off for one second and then turn back on. This is intended to cause an external chime to sound every 30 seconds until the unit is reset.

NOTE 6: Audio Source Selection

The CSD-10 has two decoder channels which are configured to monitor up to five inputs. The Channel 1 decoder activates the top half of the annunciator button, and Channel 2 controls the lower half. Channel 1 monitors three inputs in the CSD-10-5 thru -8 and one input in the CSD-10-9 and -10, and channel 2 monitors two inputs in all units. The inputs are resistively combined within the CSD-10 and each input presents a nominal 10,000 ohm input impedance, and is isolated from the other inputs on its channel by approximately 6 db. The isolation from channel 1 to channel 2 inputs is very high.

When connecting to the audio inputs of the CSD-10, the installer should be aware that if the normal squelched audio output of the radio is used, the internal summing resistors and the input-to-input isolation on a channel may cause cross-talk between the normal receive audio of the radios connected to that channel. Thus, the buffered SELCAL output of the radios should be used if at all possible. If only one radio is connected to the input for each channel, there will be no problem with cross-talk due to the SELCAL decoder.

The CSD-10 MUST be connected to the SELCAL output of HF receivers if at all possible, since the Clarifier function on the HF effects the frequency of the normal audio output and will cause the SELCAL signals to be off frequency. If the HF does not have a SELCAL output, it must be operated in AM mode whenever a SELCAL signal is expected. It will not receive the call otherwise.

For receivers without transformer outputs with HI and LO signal lines, return the CSD-10 INPUT LO lines for the appropriate channel to a ground which is physically and electrically close to the source radio to avoid ground noise pickup. Do not use volume controlled audio as input to the CSD-10. Use twisted, shielded wire to connect the audio to avoid hum and noise pickup. Any quality communications receiver may be used to receive the SELCAL signals for CSD-10 use. Commonly, VHF and HF are the most used. Connections to receivers not shown should follow the

example to the extent possible.

INSTALLATION TESTING

The following tests should be performed to verify the installation in the airplane is operating properly:

1. Apply power to the unit and press the SELF-TEST button to initiate a SELF-TEST. The lamps in the button should light and the ringer should sound continuously.
2. Using a ground test set such as the Avtech CTS-700 SELCAL/ATSCALL Ramp Test Set, select the frequency for test on one of the communication transceivers to which the CSD-10 is connected. On the test frequency generate a SELCAL encoded signal of the code sequence programmed into the CSD-10. Confirm that the appropriate section of the annunciator lamp button illuminates and the ringer is heard. Press the TEST/RESET button to reset the decoder.
3. If possible, contact the agency which will be furnishing SELCAL service to the aircraft and request a test call.

EQUIPMENT AND ACCESSORY PART NUMBERS

Avtech

Part Number	Description
1200006-005	5 radio inputs, Black Bezel
1200006-006	5 radio inputs, Grey Bezel
1200006-007	5 radio inputs, Black Bezel, No Ringer
1200006-008	5 radio inputs, Grey Bezel, No Ringer
1200006-009	3 radio inputs, Black Bezel, Lighted
1200006-010	3 radio inputs, Grey Bezel, Lighted
1200009-000	Attenuator, Audio, 20 dB
2000001-004	Connector, Cable Mounting W/Pins
1000005-001	Test Set, CTS-700 SELCAL/ATSCALL Ramp Test System, 115v/60Hz
1000005-002	Test Set, CTS-700 SELCAL/ATSCALL Ramp Test System, 220v/50Hz
8400012-000	Lens, Filter, Blue No Legend (Blank)

8400012-001	Lens,Filter,Blue	"VHF 1"
8400012-002	Lens,Filter,Blue	"VHF 2"
8400012-003	Lens,Filter,Blue	"VHF 3"
8400012-004	Lens,Filter,Blue	"HF 1"
8400012-005	Lens,Filter,Blue	"HF 2"
8400012-009	Lens,Filter,Blue	"VHF"
8400012-010	Lens,Filter,Blue	"HF"

LAMP AND LEGEND CHANGING

The normal type 327 28 volt lamps in the CSD-10 annunciator light may be changed to another voltage or replaced and the legends may be changed by removing the light insert from the front of the unit.

To remove the insert, note the finger grooves in the top and bottom of the clear plastic cover over the legends. By grasping the insert at the top and bottom with thumb and index finger the insert may be pulled straight out, exposing the base of the four lamps in the rear of the insert. Pull the lamps out the rear of the insert to remove or replace. Lamp type 328 is suggested for 5 volt operation.

The factory standard legends in the insert may be changed by removing the clear front cover of the insert, allowing access to the legend inserts. Remove the legend inserts by gently lifting one edge and pulling forward. Note that the legend insert is backed up by a clear filter plate which must be in place when the light insert is reassembled. Replace the removed legend insert with the desired one, and reverse the steps to reassemble the unit.

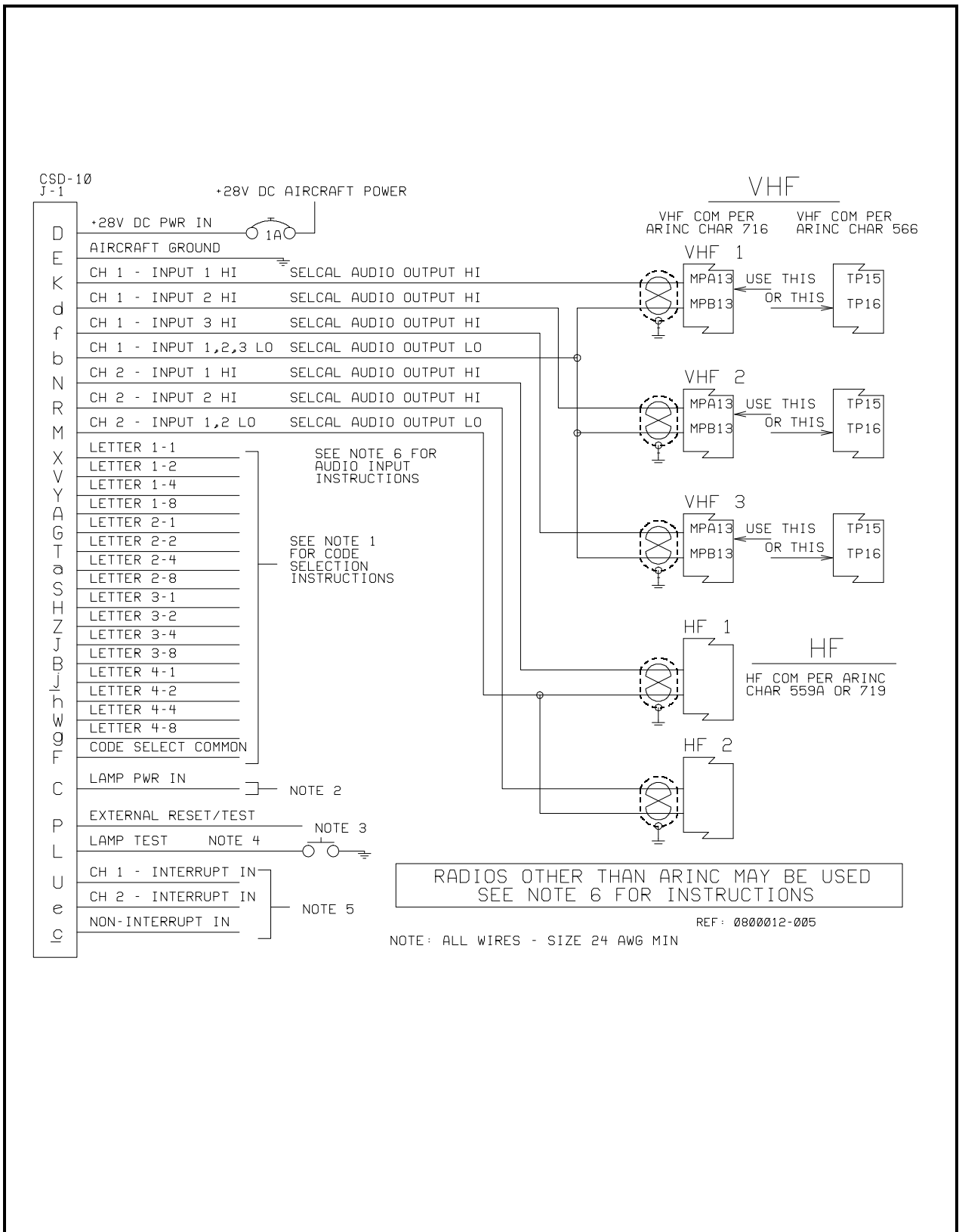

Figure 1 - CSD-10-5 thru -8 Wiring Diagram

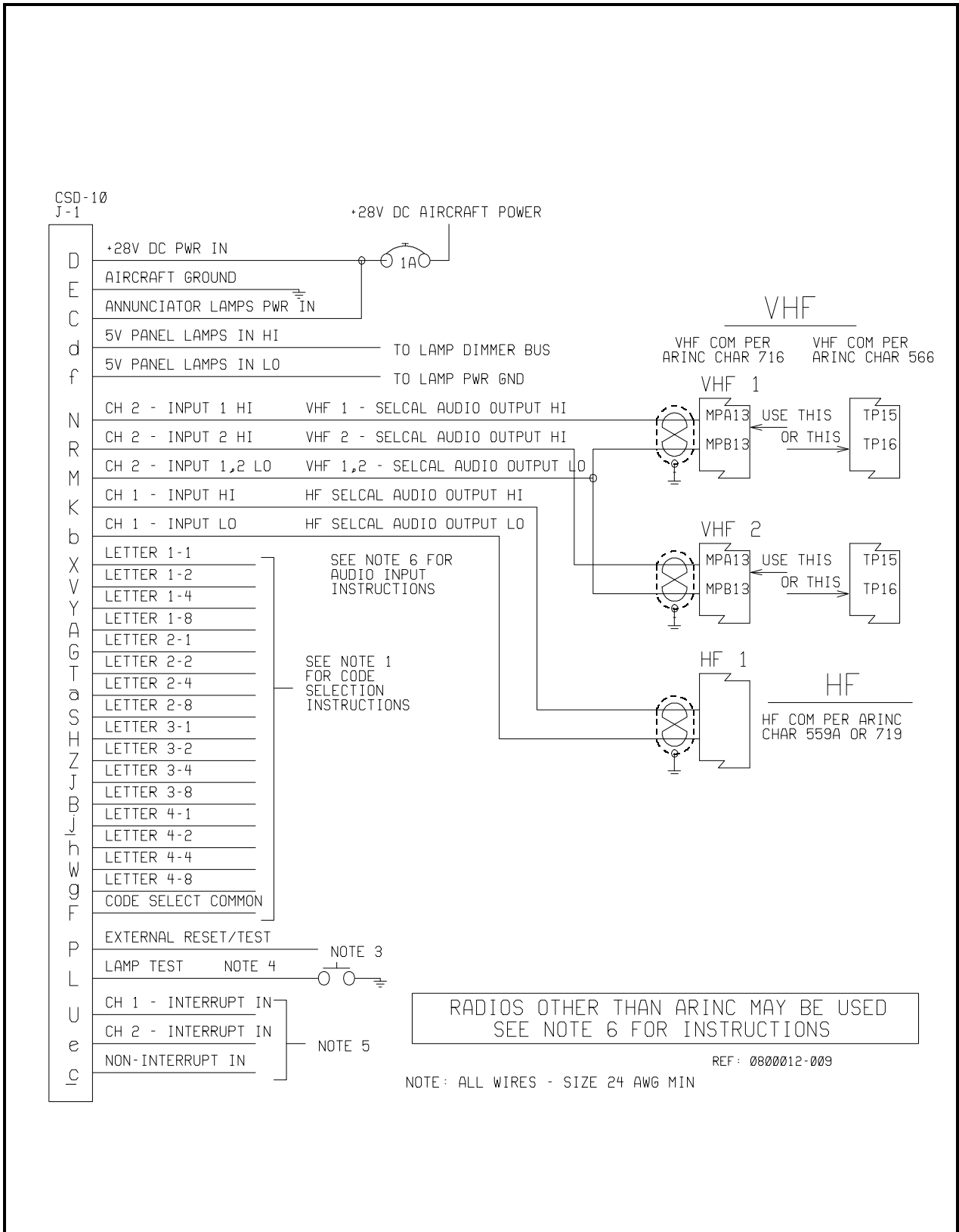

Figure 2 - CSD-10-9 and -10 Wiring Diagram

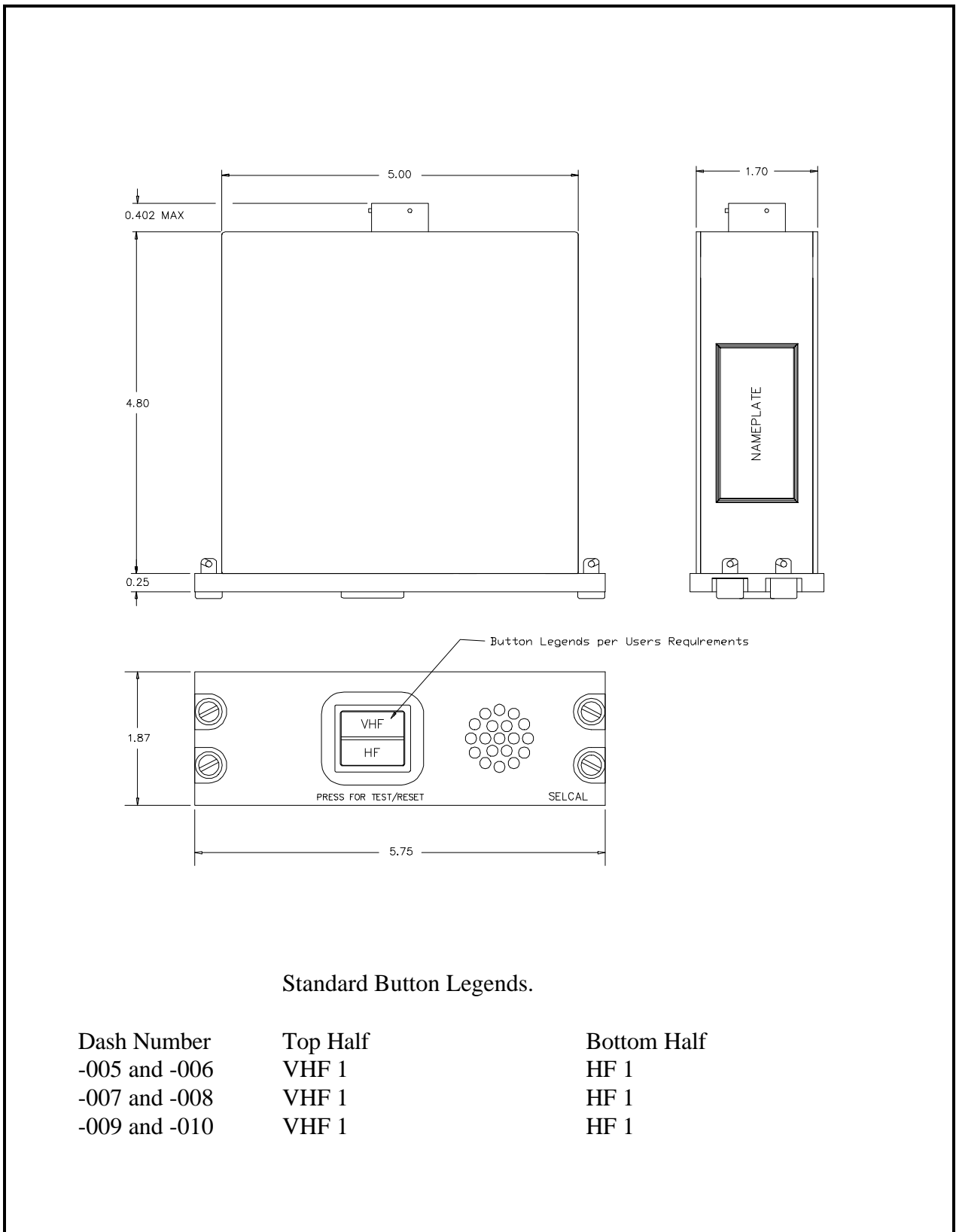

Figure 3 - Outline Drawing

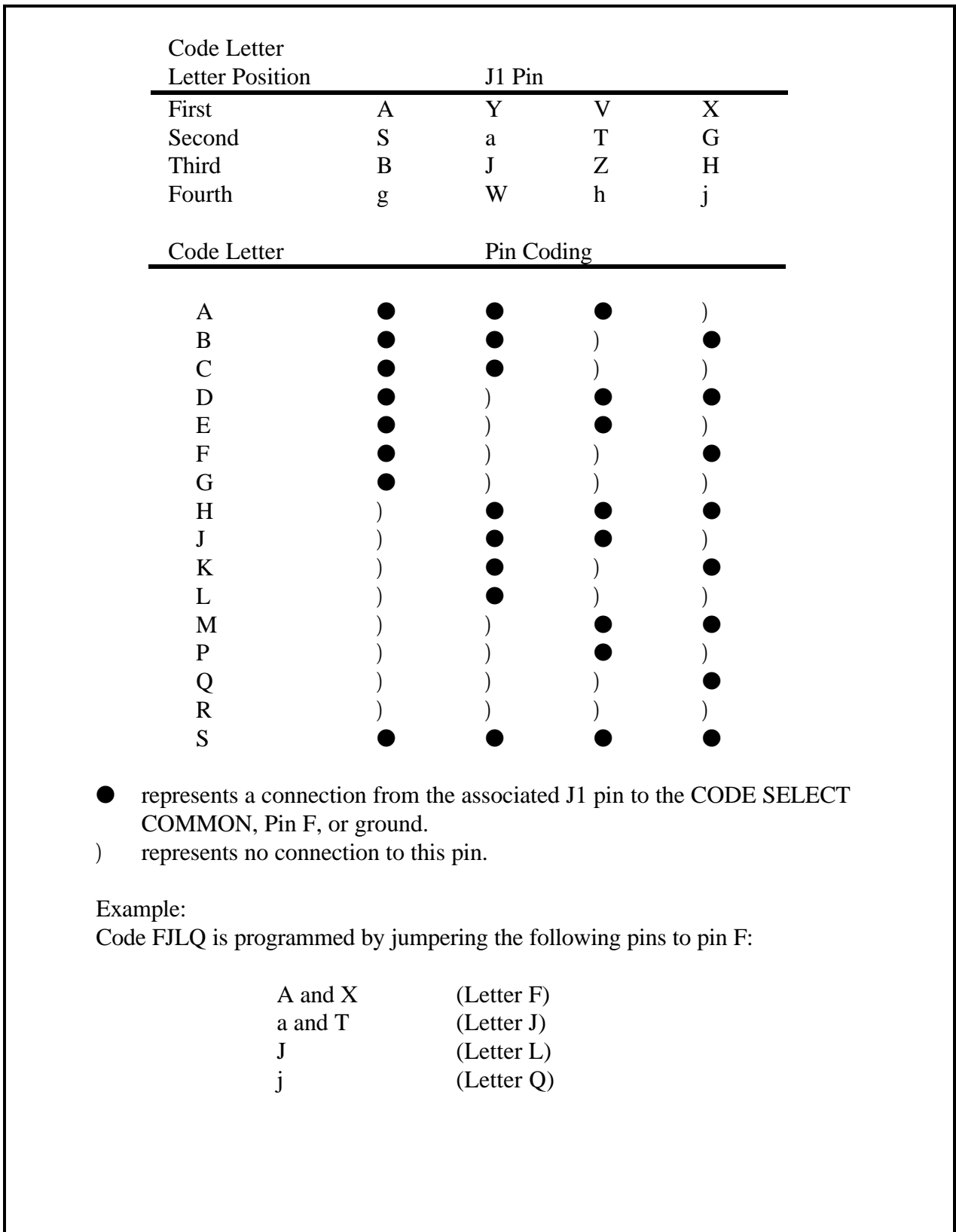

Figure 4 - Code Programming

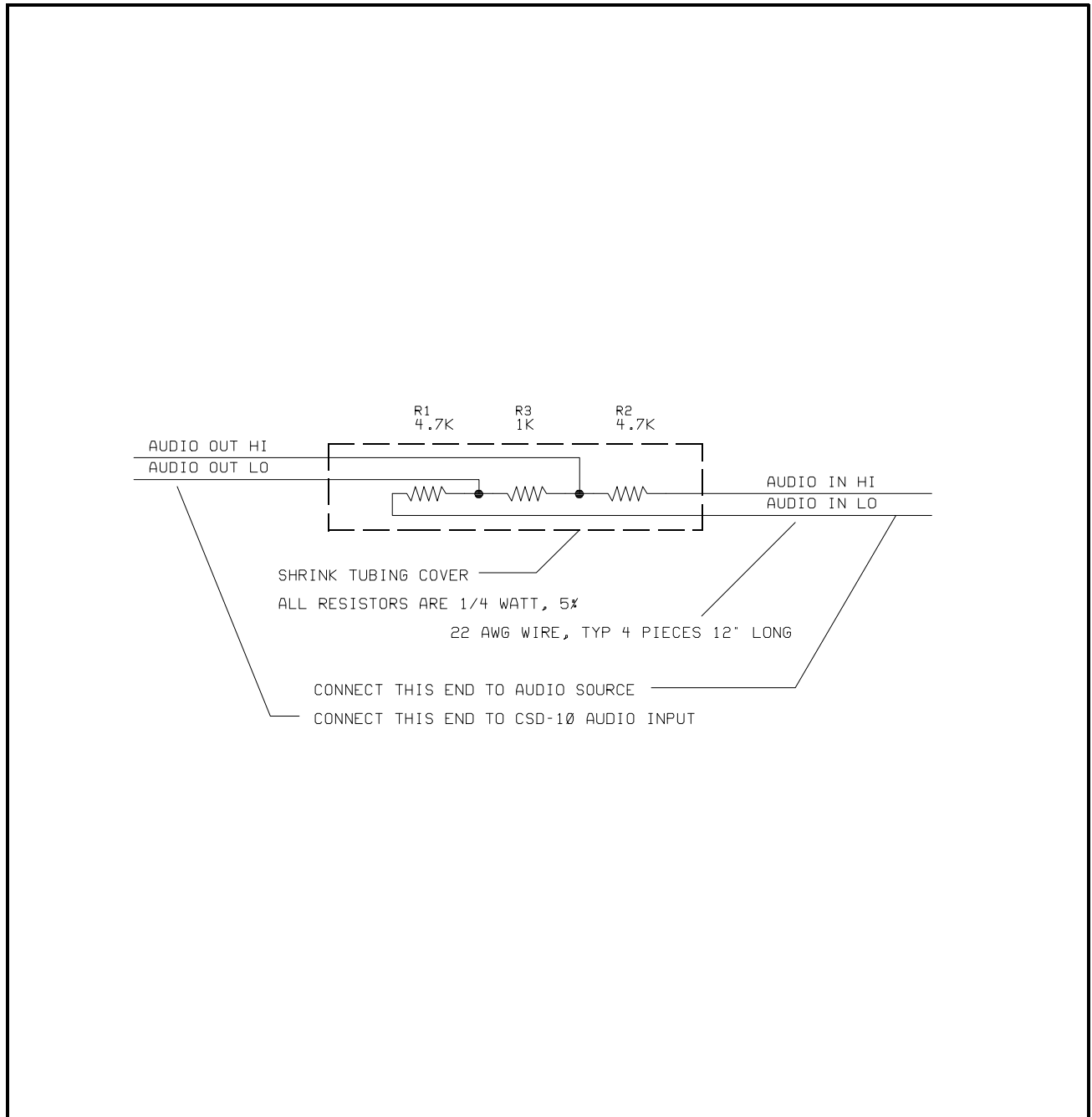

Figure 5 - 20 dB Attenuator