

DISPLAY SWITCHING UNIT (DSU)
INSTALLATION AND OPERATION PROCEDURE
AVTECH Part Number 6001-1-4

PROPRIETARY RIGHTS NOTICE

THIS DATA IS PROPRIETARY TO AVTECH CORP. DISCLOSURE, REPRODUCTION, OR USE OF THIS DATA FOR ANY PURPOSE IS NOT AUTHORIZED WITHOUT WRITTEN PERMISSION FROM AVTECH CORP.

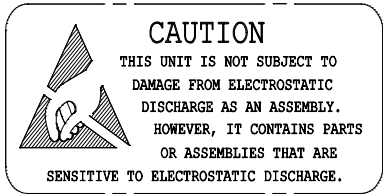

PREPARER		DATE	
PROJECT ENGINEER		DATE	
SQA		DATE	
ENGINEERING MANAGER		DATE	

CHANGE RECORD

REV	PAGE	DESCRIPTION	DATE
-----	------	-------------	------

TABLE OF CONTENTS

<u>PARA.</u>	<u>TITLE</u>	<u>PAGE</u>
1	SCOPE	1
2	DSU LIMITATIONS AND ASSUMPTIONS	1
2.1	Supported TAWS Modes	1
2.2	DCP Source Assumptions	1
2.3	DSU Fail Safe Design	2
3	PILOT OPERATION	2
3.1	Operator/DSU Input Discretes	2
3.2	Discrete Outputs	4
3.3	Power-Up Operation	4
4	DSU SYSTEM DESCRIPTION	5
4.1	DSU Built-In-Tests	5
4.1.1	Power-up BIT	5
4.1.2	Continuous BIT	5
4.2	DSU Error Messages	5
4.2.1	NO DATA	5
4.2.2	TERR STBY	6
4.2.3	TERR INOP	6
4.3	DSU Video Processing	6
4.3.1	Range Rings and TERR Text	6
4.3.2	Range Text	6
4.4	Alerts, Hold Out States and Alert Priorities	7
4.4.1	Alerts	7
4.4.2	Hold Out State	7
4.4.3	Alert Priorities	7
4.4.4	Terrain Awareness	8
4.4.5	TCAS Alert	8
4.4.5.1	Terrain Alert	8
4.4.6	No Terrain Data	8
5	INSTALLATION	9
5.1	Package Dimensions	9
5.2	Mounting Provisions	9
5.3	Input/Output Connectors	11

5.4	Weight	11
5.5	Cooling	11
5.6	Wiring	11
5.7	Installer/DSU Program Pins	14
5.8	DSU /DCP-1 Input/Output	15
5.8.1	DCP-1 Inputs to DSU	15
5.8.2	TCAS Caution/Alert Discrete	15
5.8.3	DSU Inputs to DCP-1	15
5.9	DSU/DCP-2 Input/Output	15
5.9.1	DCP-2 Inputs to DSU	15
5.9.2	DSU to DCP-2 Output	15
5.10	Installation Examples	16
5.10.1	Adding TAWS to	16
5.10.2	Adding TAWS to	18
5.10.2.1	Overlay in	20
5.10.3	Adding TAWS to	22
6	INSTALLATION TESTS	25
6.1	Basic DSU Operational Tests	25
6.1.1	WXR Indicator Calibration	25
6.1.2	TAWS Connection Test	25
6.1.3	Terrain / Weather Radar Switching Test	25
6.1.4	WXR Range Rings and TERR Range Rings Alignment Test	25
6.1.5	Terrain ON Indicator Test	25
6.1.6	DCP Range Data Test	26
6.1.7	Display Size Test	26
6.2	DCP-1 Input Tests (optional input)	26
6.2.1	DCP-1 Overlay Function Test	26
6.2.2	DCP-1 Aircraft Origin Test	26
6.2.3	Bypass Mode Test (remove DSU power)	26
6.2.4	TCAS Alert Test (pop up)	26
6.3	DCP-2 Input Tests (optional input)	27
6.3.1	DCP-2 Overlay Function Test	27
6.3.2	DCP-2 Aircraft Origin Test	27
6.4	DSU INOP Indicator Test (optional indicator)	27
6.5	DCP-1 Indicator Test (optional indicator)	27
6.6	DCP-2 Indicator Test (optional indicator)	27

7	SPECIFICATIONS	28
7.1	DSU Characteristics	28
7.2	Operational Environment	29

LIST OF TABLES

<u>TABLE</u>	<u>TITLE</u>	<u>PAGE</u>
Table 1	User Operated Inputs	3
Table 2	DSU Discrete Outputs	4
Table 3	Pin Programing of Functions	14
Table 4	Data Displayed vs. Status Output	24

LIST OF FIGURES

<u>FIGURE</u>	<u>TITLE</u>	<u>PAGE</u>
Figure 1	Outline Dimensions, 6001-1-2 DSU	10
Figure 2	DSU Connector Placement and Mating Connector Information	11
Figure 3A	Interconnect Wiring Diagram (Sheet 1)	12
Figure 3B	Interconnect Wiring Diagram (Sheet 2)	13
Figure 4	DCP Display State: No DCP Source	17
Figure 5	DCP Display State: One DCP Source, No Overlay	19
Figure 6	DCP Display State: One DCP Source, Overlay Controlled by OVRLAY_IN	21
Figure 7	DCP Display State: One DCP Source, Overlay Always Enabled	23

1 SCOPE

The Display Switching Unit (DSU) provides the capability of displaying Terrain Awareness Warning System (TAWS) information from the ACSS T²CAS onto Collins Weather Radar (WXR) Indicators that use a Display Control Panel (DCP) input. Specifically, the Collins indicators which will interface with the DSU are the IND 220, 270, 270a, and 300. The DSU provides the display information to these Collins displays in the DCP format.

The DSU switches up to three sources of display information, two of which may be simultaneously displayed. One source will always be the TAWS data in ARINC 708A/453 bus format. The one or two other sources can be any device using the DCP format output. The DSU reformats the TAWS data (ARINC 453 format) to DCP format. The data from a DCP source passes through the DSU without being reformatted. The operator has the ability to overlay one source over another using configuration pins and operator inputs.

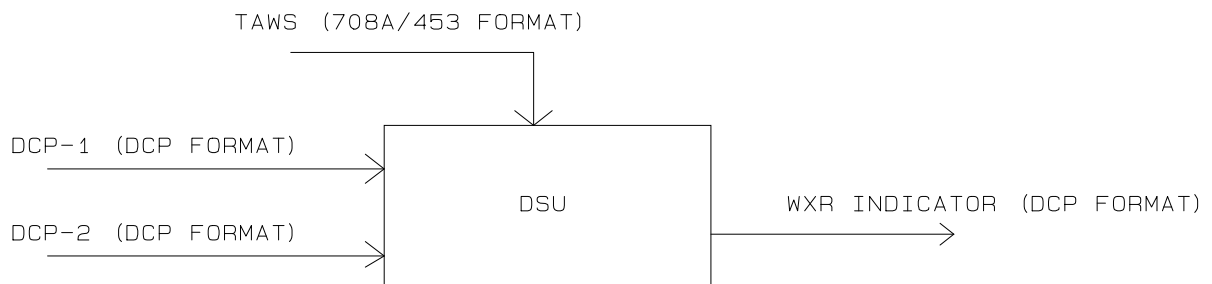

2 DSU LIMITATIONS AND ASSUMPTIONS

2.1 Supported TAWS Modes

The DSU supports only a bottom (centered horizontally) aircraft origin when using DCP overlays on Terrain. This is because the TAWS only supports a bottom centered origin.

2.2 DCP Source Assumptions

Since the DSU does not reformat the display information coming from either of the DCP sources, the following assumptions have to be made for the correct operation of the DSU.

- 1) Each DCP source must function correctly when connected directly to the DCP Display.
- 2) If used as an overlay, the aircraft origin for each DCP source must be located on the bottom (centered horizontally) of the DCP display.
- 3) When a DCP source overlays the DCP display's internal Weather Radar image, the range scale and aircraft origin position are accurate and consistent.
- 4) If a DCP-compatible TCAS source is used, it must be used on the DSU DCP-1 input and it must have TCAS alert output discrete (logic low enable). This provides TCAS alert capabilities.

If the above statements are true then the range scale and aircraft origin position will be correct when the DCP source is overlaid on TAWS data. If the above statements are not true then the DCP source should be adjusted/corrected before it is used.

2.3 **DSU Fail Safe Design**

The DSU was designed with a "fail safe" to pass through the DCP-1 data without modification in the case of DSU failure. If the DSU fails power up Built-In Test (BIT) (see section 4.1), then the DSU initiates the DCP-1 bypass mode where DCP-1 signal is routed directly to the DCP display via relays in the DSU. This fail safe design ensures that the DCP-1 device is still available to the operator even if the DSU fails.

3 **PILOT OPERATION**

Pilot operation of the DSU is limited to a minimum of one and a maximum of four externally mounted switches.

3.1 **Operator/DSU Input DisCRETes**

The operator has the capability to uniquely display the TAWS, the DCP-1, the DCP-2, or the weather radar image. The operator also has the capability to overlay the DCP-1 (or DCP-2) image on either the TAWS, DCP-2 (DCP-1), or the weather radar image. This is accomplished by either switching the TERR_IN, UDI1/2_IN, and OVRLAY_IN Operator Input discretes, or as a result of the Program Pins (see section 5.7). The state of each Operator Input discrete is changed by presenting a momentary ground (which shall be > 50 msec) to the pin associated with each discrete. A subsequent momentary ground shall again change the state of the pin switching the state between active and inactive.

It is expected that a Terrain button will be present in all installations of the DSU. If the Terrain button is not installed, the operator will not be able to view the TAWS data except when a Terrain Alert occurs (see section 4.4.5.1). It is also understood that Operator Inputs described below, other than Terrain, are optional and may not be part of the installation. In these cases, DSU operation will be uniquely determined by the state of the Program Pins.

Table 1 - User Operated Inputs		
Pin Name (Refer to Fig. 3)	Connector Pin Number	Function
TERR_IN	J1-2	If the Terrain input is active, the DSU will use the TAWS input as the base video image. The operator controls the TERR_IN discrete by momentarily depressing the Terrain switch. The default at power-up will be inactive (DCP-1 is used as the base image).
OVRLAY_IN	J1-1	If the Overlay input is active and the OVRLY_IN_EN Program Pin is active (refer to section 5.7), the DSU will overlay the video source selected by the OVRLY_PRI Program Pin on the base image. Otherwise, the base image will be sent to the DCP Display by itself. The operator controls this discrete by momentarily depressing the Overlay switch. The default at power-up will be inactive (overlay image off).
UDI1/2_IN	J1-3	If the UDI12_IN_EN Program Pin is active (refer to section 5.7) and the Terrain switch and overlay switch are not active, this discrete toggles between the DCP-1 and the DCP-2 as a source for the base image. The operator controls this discrete by momentarily depressing the UDI1/2_IN switch. The default at power-up will be inactive (DCP-1).
DSUOUT_IN	J1-4	If this switch is inactive and the DSUOUT_IN_EN Program Pin is active (refer to section 5.7), the DSU will not output an image to the DCP Display. Otherwise, the DSU outputs the appropriate screen image as defined by the Operator Inputs, the Program Pins, and alerts. The operator controls this function by momentarily depressing the DSU INHIBIT switch. The default at power-up will be active (DSU Output Enabled).

3.2 Discrete Outputs

The DSU has a total of four discrete outputs. The discrete outputs indicate the overall health and status of the DSU. When active, each output provides a ground (active, < 10 kohms). When inactive, each output provides an open circuit (inactive, > 1Mohm). Each output is current limited to 200 mAmps.

Table 2 - DSU Discrete Outputs		
Pin Name (Refer to Fig. 3)	Connector Pin Number	Function
DISPLAY_INVALID	J1-7	The DISPLAY_INVALID discrete output indicates the health of the DSU. This discrete is active during power up and will become inactive when the DSU successfully passes all power-up BIT tests. If the DSU fails any power-up BIT test or if the unit is reset, the discrete will remain active.
TERR_STATUS	J2-32	The TERR_STATUS discrete output is active when the DSU generated output contains TAWS data (either by itself or with an overlay). Otherwise, it is inactive.
UDI1_STATUS	J2-33	The UDI1_STATUS is active when the DSU generated output to the DCP display contains the DCP-1 data. Otherwise, it is inactive.
UDI2_STATUS	J2-34	The UDI2_STATUS is active when the DSU generated output to the DCP display contains the DCP-2 data. Otherwise, it is inactive.

3.3 Power-Up Operation

The DSU is operational within 5 seconds in ambient temperatures above -30 degrees C. In ambient temperatures between -40 degrees and -30 degrees C, the DSU is operational within five minutes after power is applied. In ambient temperatures between -55 degrees and -40 degrees C, the DSU is operational within 20 minutes after power is applied. This allows the DSU's internal heater to elevate internal component temperatures.

Upon initial power-up, the DSU sets the DISPLAY INVALID Output Discrete to active (ground) and sets the bypass relay to active, thereby connecting the DCP-1 input video source directly to the DCP display.

4 **DSU SYSTEM DESCRIPTION**

4.1 **DSU Built-In-Tests**

4.1.1 Power-up BIT

The DSU executes a power-up BIT before going into normal operation. If all tests pass, the DSU sets the DISPLAY INVALID output discrete inactive (open) and the bypass relay to inactive, thereby allowing the DSU to control the data sent to the DCP display. If any power-up BIT fails, it keeps the DISPLAY INVALID output discrete active (closed) and reports a DSU BIT failure to the TAWS via ARINC 429. During power-up BIT the DSU verifies the ROM Checksum, performs a RAM test, checks the processor communication and tests the external watchdog timer.

4.1.2 Continuous BIT

The DSU executes the continuous BIT during normal operation. The continuous BIT monitors the TAWS data bus (ARINC 453) for valid data and checks the range selected on the DCP Display for correctness. If the DSU finds invalid TAWS data for more than two seconds, a yellow warning message stating, "NO DATA" is sent to the DCP display and the DSU reports the failure to the TAWS via ARINC-429. If the DSU finds invalid range bit code data for more than two seconds, it reports the failure to the TAWS via ARINC-429 message.

4.2 **DSU Error Messages**

The DSU converts the terrain data from the TAWS from an ARINC 453 format to a DCP format but does not modify the content of the image. The following are special error messages that may appear on the DCP display. They result from TAWS or DSU error conditions. All error messages are displayed in yellow and are centered on the DCP display. All error messages are erased and the display returns to normal operation when the error condition goes away and the Hold Out State has elapsed. (see section 4.4.2 for definition of Hold Out State).

4.2.1 NO DATA

This message written to the DCP display by the DSU indicates that the TAWS (ARINC 453) data has been invalid for more than two seconds.

4.2.2 TERR STBY

This message written to the DCP display by the DSU indicates that the TAWS Terrain Awareness State is “not available” or “inhibited” and terrain data is presently not available.

4.2.3 TERR INOP

This message written to the DCP display by the DSU indicates that the TAWS Terrain Awareness State is “INOP” and the terrain data is not valid. Refer to the TAWS documentation for more details.

4.3 **DSU Video Processing**

The DSU has one video image which is sent to the DCP display. This image can be data from single input source passed through with no modifications or a combination of the data from input sources and DSU generated data.

4.3.1 Range Rings and TERR Text

If the TAWS data is being used as a video source, the DSU superimposes two concentric range rings and the text “TERR” on the displayed image. The outer ring is set to the TAWS range setting (the extent of the radar screen). The inner ring is set to ½ the range. For example, if the range is set to 25 NM, the outer ring will be at 25 NM with the inner ring set at 12.5 NM. The inner range ring is not displayed when there is no TAWS (ARINC 453) Label 055 data. The “TERR” text is displayed in white and is placed in the lower left corner of the display.

4.3.2 Range Text

The range information from the TAWS data is displayed on the DCP display as text in the upper right hand corner of the display. For example, if the range is set to 2 nautical miles, “2” appears on the upper right corner of the display. The range text is not displayed when there is no TAWS (ARINC 453) Label 055 data.

The operator utilizes the weather radar display to request a range. Hence the TAWS uses the range information from the DSU via the 429 bus to determine how the image data from the TAWS should be scaled. There will be some delay between time of request of a change in range, and the availability of an updated image. If the DSU determines that the display range is different than the range in the TAWS data, the DSU flashes the displayed range text.

4.4 Alerts, Hold Out States and Alert Priorities

4.4.1 Alerts

There are two alert conditions that will cause the DSU to change the output to the DCP display. One of these conditions is an active Warning alert from the TAWS or DCP-compatible TCAS. The other condition is where the TAWS data can't be used, so the DSU replaces the display data with an error message. The conditions are described in the sections that follow.

4.4.2 Hold Out State

When any alert condition occurs, a two-second Hold Out State is initiated. While in a Hold Out State, all other alerts are ignored for two seconds. If Terrain Warning or TCAS Alert conditions triggered the Hold Out State, then the DSU will also ignore Operator Inputs during the two second period. When an alert condition exists, the DSU changes the state of the Operator Inputs and the Overlay Program Pin as if the operator had pushed the buttons or disconnected the pin.

Any message that initiates a Hold Out State will be displayed for the whole two-second period. When the Hold Out State has expired, the DSU will again respond to Operator Inputs and new alerts. If the Overlay Program Pin state was modified for the Hold Out State, it reverts to its programmed value when the TERR button or the UDI1/2_IN button is pressed.

4.4.3 Alert Priorities

In the case of simultaneous alert conditions, the DSU responds to the highest priority alert. The priorities are defined as follows:

Highest	1. Terrain Alert
	2. TCAS Alert
Lowest	3. No Terrain Data

It is expected that the Terrain Alert and TCAS Alert will last longer than two seconds. If one of these occurs during an existing Hold Out State, it will be recognized when the Hold Out State is over and a new Hold Out State will be entered. If an alert is shorter than two seconds and occurs during an existing Hold Out State, it will not be recognized or displayed.

4.4.4 Terrain Awareness

The DSU monitors the Terrain Awareness State from TAWS data and modifies the DSU status as described in the following paragraphs.

4.4.5 TCAS Alert

The DSU monitors the TCAS caution/alert discrete signal from DCP-1 (see section 5.8.2). If the discrete transitions from inactive to active and a Hold Out State is not active, the DSU forces the TCAS data only to be sent to the DCP Display by changing the state of the input discretes to the following:

Terrain Input Discrete :	Inactive
UD11/2_IN Input Discrete:	DCP-1
Overlay Input Discrete:	Inactive
DSU Output Input Discrete:	Active
Overlay Program Pin:	Inactive

The DSU then enters a Hold Out State and ignores Operator Inputs for two seconds.

4.4.5.1 Terrain Alert

If the Terrain Awareness State transitions to Warning, the DSU forces the DCP display to show only TAWS data by changing the state of the input discretes to the following:

Terrain Input Discrete :	Active
Overlay Input Discrete:	Inactive
DSU Output Input Discrete:	Active
Overlay Program Pin:	Inactive

The TAWS data is shown at 10 NM range after a Terrain Alert. The DSU then enters a Hold Out State and ignores Operator Inputs for 2 seconds.

4.4.6 No Terrain Data

If the DSU determines that the TAWS data is invalid for two seconds, it replaces the current TAWS display data with the message NO DATA centered on the screen in yellow and sets the state of the input discretes as follows:

Terrain Input Discrete :	Inactive
Overlay Input Discrete:	No change
DSU Output Input Discrete:	No change
Overlay Program Pin:	No change

The DSU then enters a Hold Out State for 2 seconds.

5 **INSTALLATION**

5.1 **Package Dimensions**

The DSU package dimensions are described in **Figure 0**.

5.2 **Mounting Provisions**

No special vibration or shock provisions are required. The DSU can be mounted in any orientation except upside down. DSU mounting is provided via two flanges, running along the bottom edge of the longer of the two rectangular dimensions. Each flange provides two mounting through-holes designed for usage of number 6 mounting hardware. Mounting hole dimensions are shown in **Figure 0**.

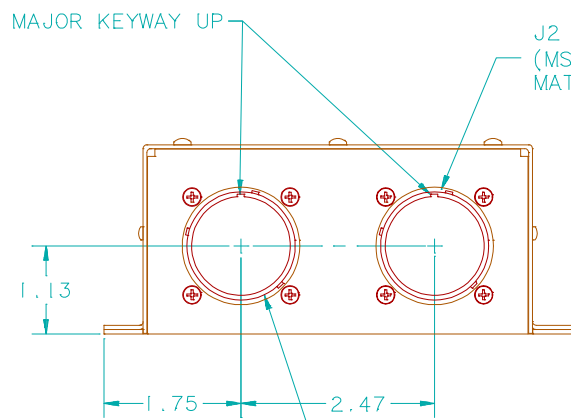
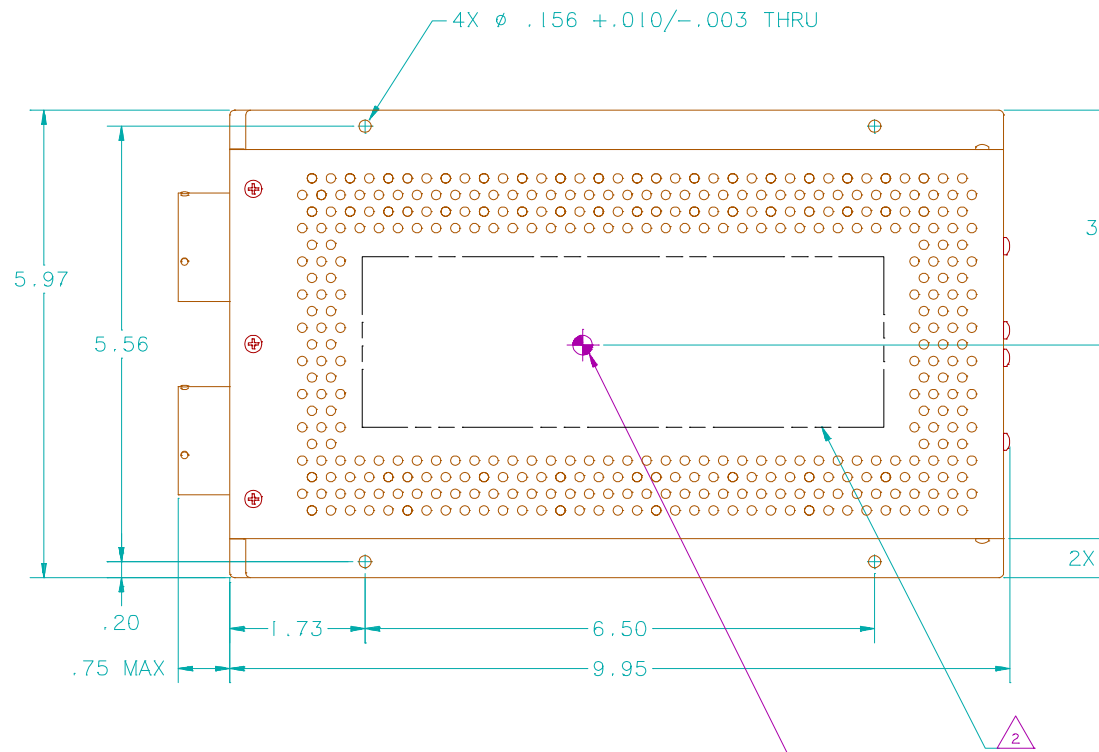

J2
 (MS24264R22B55PN WITH PC PINS)
 MATES WITH MS24266R22B55SN

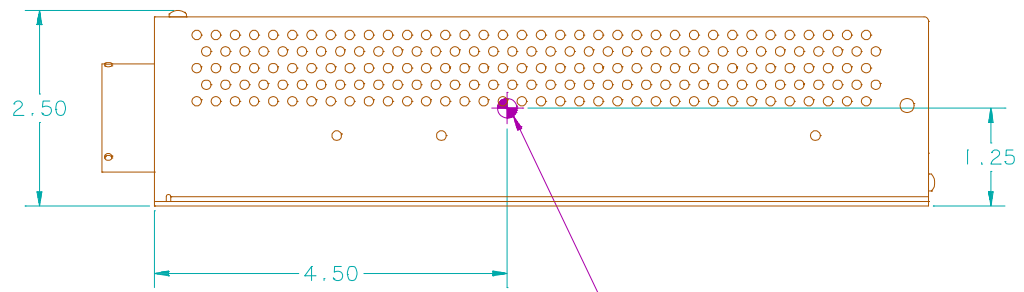

J1
 (MS24264R22B55P6 WITH PC PINS)

5.3 Input/Output Connectors

The DSU has two input/output connectors. Both connectors are per MIL-C-26500, Class R, Type B, Plug Shell Size 22, Arrangement 55, 55 each #20 socket contacts, polarization types 6 and N. The connectors are designated J1 and J2. The J1 connector is polarization type 6, and the J2 connector is polarization type N. Refer to **Figure 2** for mating connector part numbers and placement.

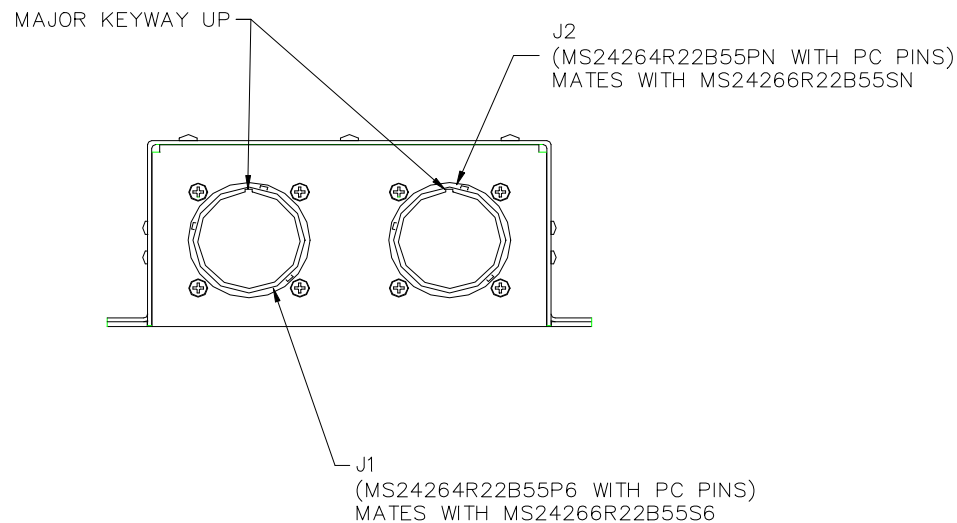

Figure 2 DSU Connector Placement and Mating Connector Information

5.4 Weight

The weight of the DSU shall not exceed 2.81 lbs / 1.27 kg.

5.5 Cooling

The DSU is cooled by conduction and free convection. Neither fans nor external forced air cooling are required.

5.6 Wiring

Figure 3 shows the system level interconnect wiring diagram for the DSU. The figure includes wire type, size, and connectivity.

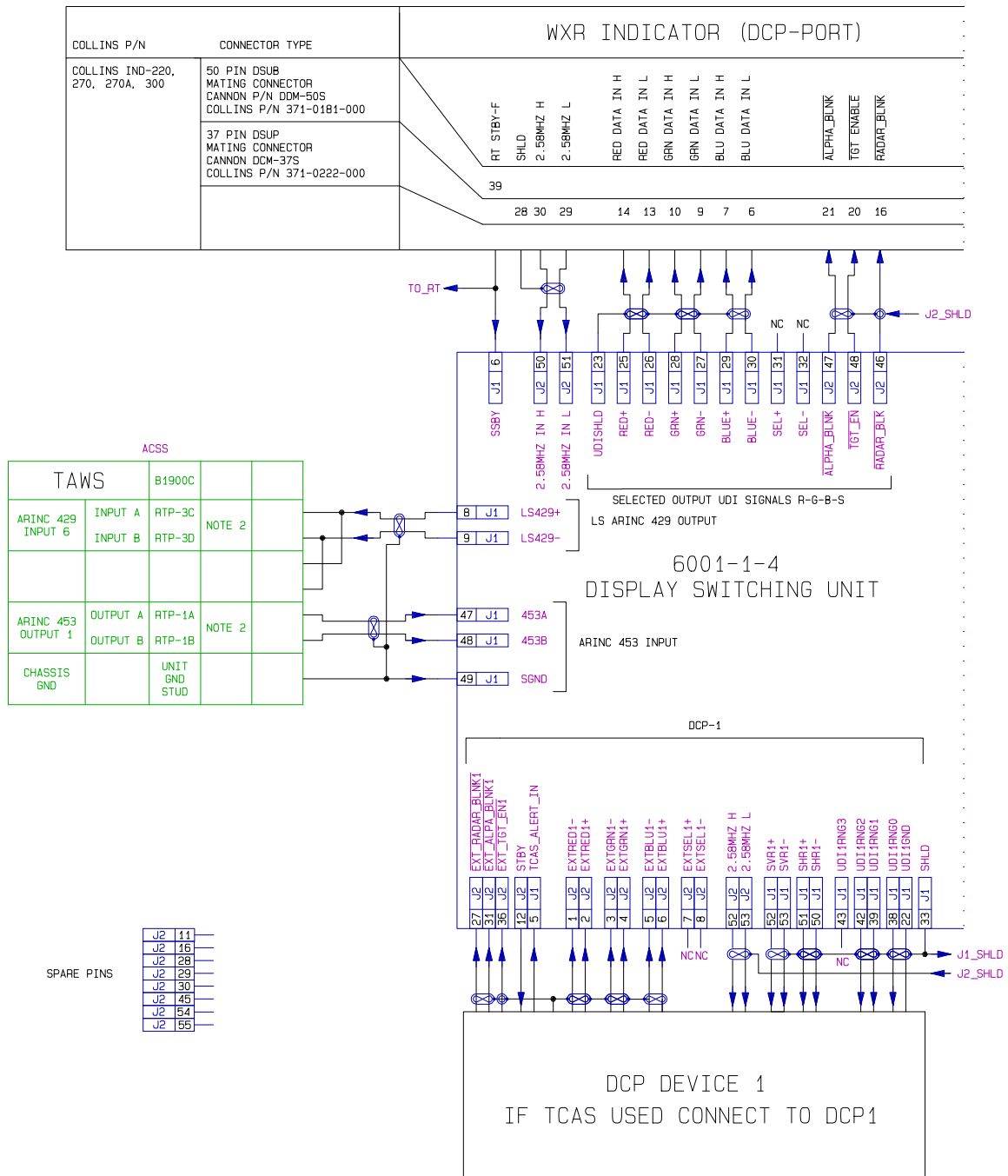

Figure 3A Interconnect Wiring Diagram (Sheet 1)

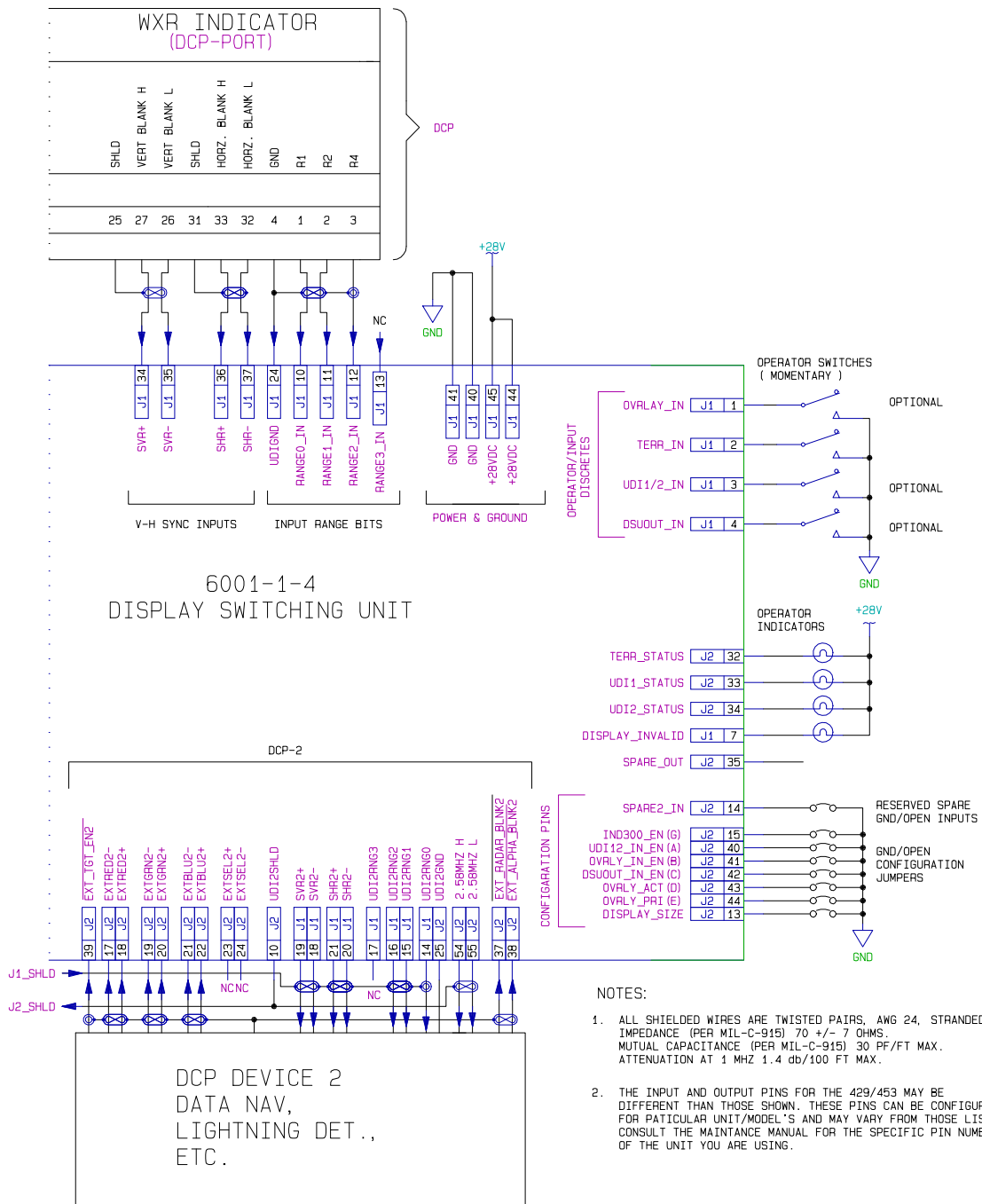

Figure 3B Interconnect Wiring Diagram (Sheet 2)

5.7 Installer/DSU Program Pins

The DSU provides six Program Pins which are used by the installer to enable DSU functions. The states of these pins are read during initial power-up. The programming is accomplished by either connecting any of these pins to ground or leaving the pin open.

Table 3 - Pin Programing of Functions			
Program Pin Function Name	Pin Name (Refer to Fig. 3)	Connector Pin Number	Function
UDI1/2_IN Operator Input Discrete Enable	UDI12_IN_EN(A)	J2-40	If this pin is grounded, the DSU reads the status of a momentary push button attached to the UDI1/2_IN Operator Input Discrete Pin (refer to section 3.1). Otherwise, the Operator Input will be ignored.
OVERLAY Operator Input Discrete Enable	OVRLY_IN_EN(B)	J2-41	If this pin is grounded, the DSU reads the status of a momentary push button attached to the OVRLY_IN Operator Input Discrete Pin (refer to section 3.1). Otherwise, the Operator Input will be ignored.
DSU Output Operator Input Discrete Enable	DSUOUT_IN_EN(C)	J2-42	If this pin is grounded, the DSU reads the status of a momentary push button attached to the DSUOUT_IN Operator Input pin (refer to section 3.1). Otherwise, the DSU Output Operator Input will be ignored.
OVERLAY Active/Inactive	OVRLY_ACT(D)	J2-43	If this pin is grounded, the input video source specified by the OVRLY_PRI Priority Program Pin will be overlaid on the base video image. Otherwise, the base image will be sent to the DCP Display by itself. This discrete will be ignored if the OVERLAY Operator Input Discrete Enable is active.
OVERLAY Priority	OVRLY_PRI(E)	J2-44	If this pin is grounded, the DSU will use DCP-1 as the overlay input source. Otherwise, DCP-2 will be used as the overlay input source.
Display Size	DISPLAY_SIZE(F)	J2-13	Reserved.
IND300 Enable	IND300_EN(G)	J2-15	If this pin is grounded, the DSU will configure itself for use with an IND300 DCP Display. If grounded, Terrain Data will display without the Aircraft Origin icon. The 250nm Range Code is interpreted as 300nm.

5.8 **DSU /DCP-1 Input/Output**

5.8.1 DCP-1 Inputs to DSU

Any DCP device can be connected to the DCP-1 DSU port. However, if a DCP-compatible TCAS device is to be connected to the DSU, it must be connected to the DCP-1 port. The DCP-1 port supports the TCAS Caution/Alert Discrete (Section 5.8.2) and the TCAS alert function (Section 4.4.5). The DCP-2 port does not.

The DSU DCP-1 video input travels through a bypass relay in the DSU. The bypass relay circuitry ensures that the DSU will not cause a reduced safety condition by blocking DCP-1 in case of a DSU failure or loss of DSU power. If the DSU has failed and/or is without power, the bypass relay connects the DCP-1 video directly to the DCP display. If the DSU has powered-up and is operating normally, the bypass relay causes the DCP-1 input to be routed through the control logic of the DSU as discussed below.

5.8.2 TCAS Caution/Alert Discrete

The DSU monitors the TCAS caution/alert discrete. The DSU pin associated with the caution/alert discrete is pulled up by the DSU to a nominal 5 volts. The discrete is considered active when the pin is grounded for at least 50msec and inactive when the pin is open for at least 50msec. See section 4.4.5 for details.

5.8.3 DSU Inputs to DCP-1

The DSU outputs the range bits, the horizontal and vertical sync signals, and the standby discrete.

5.9 **DSU/DCP-2 Input/Output**

5.9.1 DCP-2 Inputs to DSU

Any Data/Nav/Lightning DCP device may be connected to the DSU as the DCP-2 device. (If there is no TCAS device, the DATA/NAV/Lightning device must be connected to the DCP-1 since the DCP-1 input is connected directly to the DCP display in case of a DSU fault or power off condition.)

5.9.2 DSU to DCP-2 Output

The DSU outputs the range bits and the horizontal and vertical sync signals.

5.10 Installation Examples

The combinations of DCP inputs, Operator Inputs, and program pin settings provides the DSU with a wide range of installation options. This section describes some of the typical installations.

5.10.1 Adding TAWS to System with no DCP sources

The simplest DSU installation adds TAWS to a system that does not have any DCP sources connected to the DCP display. Only one switch needs to be added to the system; the TERR_IN Operator Input discrete (J1-2). Basic operation of this configuration involves momentary closure of the TERR_IN switch to toggle the DCP display between WXR and TAWS terrain data. The TAWS will automatically force the DSU to change the display to show terrain data upon a Terrain Warning. See **Figure 4** for the DCP display states for a system with no DCP source.

The only program pin that might be needed is the EN300_EN(G) program pin (J2-15) which is set based on the DCP display model number. All other program pins are left open.

This installation requires connecting the DSU to the TAWS' ARINC 453 outputs and ARINC 429 inputs and to the DCP display's DCP input and range outputs (see Figure 3A). The DSU DCP-1 and DCP-2 inputs are left unconnected.

The TERR_STATUS (J2-32) may be used to monitor the state of the DCP display. The output will be active if the DSU is sending out terrain data, inactive otherwise. The DISPLAY_INVALID (J1-7) discrete output may be used to monitor the health of the DSU.

CONFIGURATION:
VIDEO INPUTS:TAWS TERRAIN
OVERLAY? NO
OVERLAY PRIORITY: N/A
OPERATOR INPUTS USED:
TERR_IN
PROGRAM PIN STATES:
UDI12_IN_EN = OPEN
OVRLY_IN_EN = OPEN
DSUOUT_IN_EN = OPEN
OVRLY_ACT = OPEN
OVRLY_PRI = OPEN
EN300_EN = display dependent

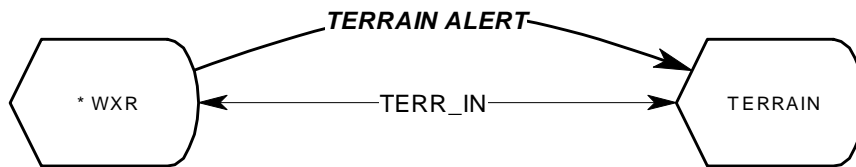

* = Power Up State **BOLD ITALICS** = Alert

Figure 4 DCP Display State: No DCP Source

5.10.2 Adding TAWS to System with one DCP source

Without a DSU, a system with one DCP source (such as a Data/Nav, Lightning Sensor, TCAS, or DCP) would have the DCP source connected directly to the DCP display's DCP input producing a display composed of a combination of DCP input data and WXR data. This section describes a DSU installation which adds TAWS to such a system. Optional overlay functions are also described for this installation.

The installation requires connecting the DSU to the TAWS' ARINC 453 outputs and ARINC 429 inputs and to the DCP display's DCP input and range outputs (see Figure 3A). For this example, the DCP source will be connected to the DSU's DCP-1 input with the DCP-2 input left unconnected.

At a minimum, one switch must be added to the system; the TERR_IN Operator Input discrete (J1-2). Operation of this basic configuration involves momentary closure of the TERR_IN switch to toggle the DCP display between a combination of DCP-1 data overlaid on WXR data or TAWS terrain data by itself. See **Figure 4** for the DCP display states for a system with one DCP source without overlay capability.

Section 5.10.2.1 describes how the overlay function operates. Regardless of the type of overlay function used, when configuring the DSU, the following points should be considered:

- a) The DSU will force the DCP display to show only terrain data upon a Terrain Warning from the TAWS.
- b) The IND300_EN(G) program pin (J2-15) has to be set to the appropriate state based on the DCP display model number.
- c) A DCP-compatible TCAS device must be connected to the DCP-1 input of the DSU in order for the DSU to properly handle TCAS alerts. The connection must include the alert output from the TCAS to the active-low TCAS ALERT INPUT (J1-5) of the DSU. The DCP-2 input of the DSU does not provide a TCAS alert input.
- d) The DSU routes the DCP-1 image to its output when it is powered down or if it fails Power-Up BITE tests.

CONFIGURATION:
 VIDEO INPUTS: TAWS TERRAIN and DCP 1
 OVERLAY? NO
 OVERLAY PRIORITY: N/A
 OPERATOR INPUTS USED:
 TERR_IN
 PROGRAM PIN STATES:
 UDI12_IN_EN = OPEN
 OVRLY_IN_EN = OPEN
 DSUOUT_IN_EN = OPEN
 OVRLY_ACT = OPEN
 OVRLY_PRI = OPEN
 IND300_EN = display dependent

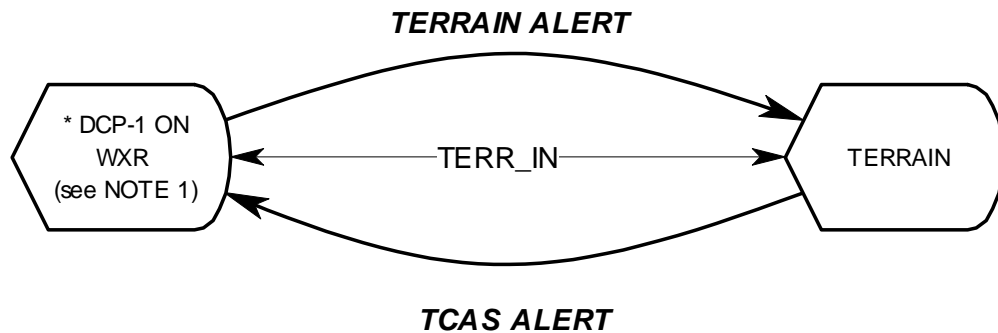

*** = Power Up State *BOLD ITALICS* = Alert**

NOTE 1: DCP-1 video must be disabled at the source to display WXR only

Figure 5 DCP Display State: One DCP Source, No Overlay

- e) The TERR_STATUS (J2-32) and DCP1_STATUS (J2-33) discrete outputs may be used to monitor the state of DSU output to the DCP display. The outputs reflect the data combinations being sent by the DSU; DCP-1 only (only DCP1_STATUS active), terrain only (only TERR_STATUS active), or terrain with DCP-1 as overlay (TERR_STATUS and DCP1_STATUS active). The DISPLAY_INVALID (J1-7) discrete output may be used to monitor the health of the DSU.
- f) The DSUOUT_IN Operator Input discrete (J1-4) may be added to this configuration. This momentary-closure input allows the user to turn-off the DSU output to the DCP display allowing it to display WXR data only. Subsequent activation of the DSUOUT_IN Operator Input discrete restores the previous DSU output. Use of the DSUOUT_IN Operator Input discrete is enabled by grounding the DSUOUT_IN_EN program pin (J2-42).

5.10.2.1 Overlay in a One DCP source System

Overlay capability, which is a standard feature of the DCP interface, provides a means to display data from more than one source on a DCP display at the same time. For each pixel on the DCP display, the data (DCP or WXR) displayed at each particular point is based on the value of the DCP sourced pixel's enable signal. If the enable for the pixel is inactive then the WXR value is displayed at that particular point on the DCP display. If the pixel is enabled then the pixel data from the DCP source is displayed. When a DCP image is overlaid on a WXR image the WXR image is defined as the "base image".

Besides adding TAWS to a system, the DSU also provides further control of overlay and base image through the use of the OVRLAY_IN Operator Input discrete (J1-1) when enabled by grounding the OVRLY_IN_EN program pin (J2-41). In addition, the OVRLY_PRI program pin (J2-44) must be grounded to define the DCP-1 input as the overlay image. For this one DCP source system the DSU will, with the combination of the OVRLAY_IN and TERR_IN Operator Input discrettes, allow overlay of the DCP-1 image, one of two base images (WXR data or TAWS terrain data) or it can display the WXR data or terrain data by itself with no overlay.

CONFIGURATION:
 VIDEO INPUTS: TAWS TERRAIN and DCP 1
 OVERLAY? YES
 OVERLAY PRIORITY: DCP 1
 OPERATOR INPUTS USED:
 TERR_IN and OVRLAY_IN
 PROGRAM PIN STATES:
 UDI12_IN_EN = OPEN
 OVRLY_IN_EN = GROUNDED
 DSUOUT_IN_EN = OPEN
 OVRLY_ACT = OPEN
 OVRLY_PRI = GROUNDED
 IND300_EN = display dependent

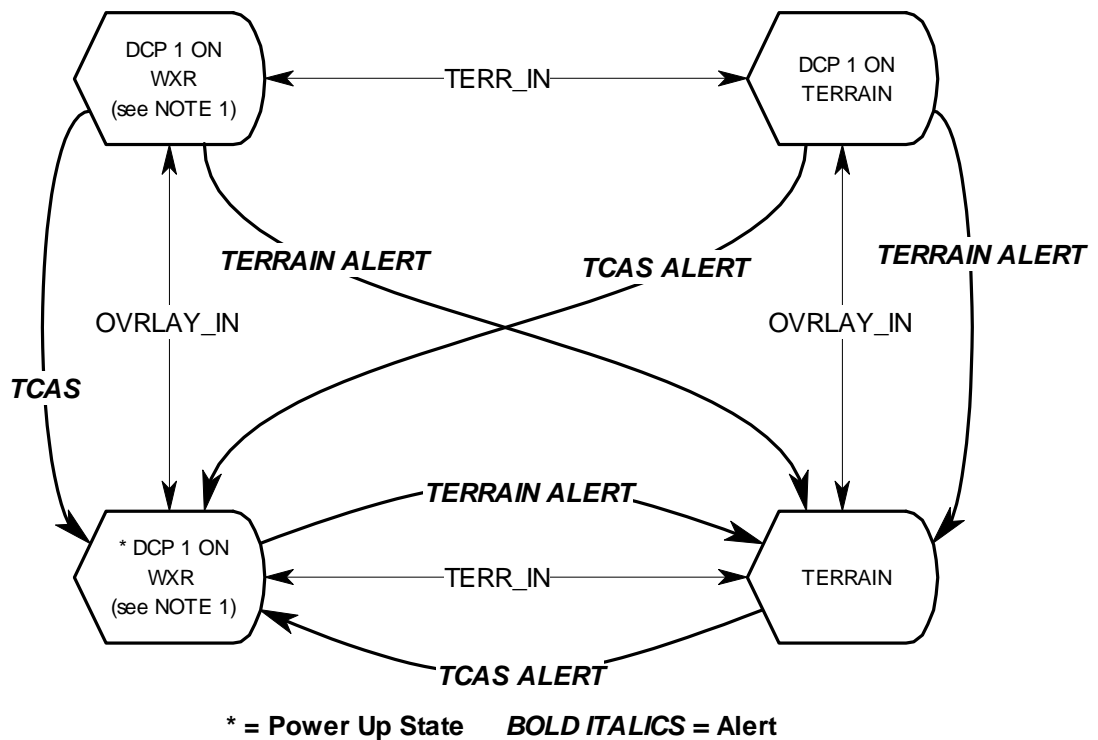

NOTE 1: DCP 1 video must be disabled at the source to display WXR only

Figure 6 DCP Display State: One DCP Source, Overlay Controlled by OVRLAY_IN

An alternative overlay configuration provides overlay without the need of a switch to control the OVRLAY_IN Operator Input discrete. The DCP-1 image will always be overlaid on WXR data or TAWS terrain data depending on the state of the TERR_IN Operator Input discrete. This configuration is attained by grounding the OVRLY_ACT program pin (J2-43) and leaving the OVRLY_IN_EN program pin (J2-41) open. In addition, the OVRLY_PRI program pin (J2-44) must be grounded to define the DCP-1 input as the overlay image.

The DSU will force the DCP display to show only terrain data, deactivating any overlay, upon a Terrain Warning alert from the TAWS. The OVRLAY_IN Operator Input discrete must be used to restore the overlay. For systems using the OVRLY_ACT program pin, the overlay is restored upon activation of the TERR_IN Operator Input discrete. See **Figure 6** for the DCP display states for a system with one DCP source with overlay always enabled.

5.10.3 Adding TAWS to System with two DCP Sources

This section discusses additional considerations over those discussed for one DCP source systems (section 5.10.2) when adding a TAWS and a DSU to a system with two DCP sources.

In a two DCP source system, the DCP sources will be connected to the DSU DCP inputs. An additional input switch is required for the DCP1/2_IN Operator Input discrete (J1-3) to allow the user to select which DCP source is output by the DSU. Use of the DCP1/2_IN Operator Input discrete is enabled by grounding the DCP1/2_IN_EN program pin (J2-40).

Remember that if a TCAS device is one of the DCP sources then it must be connected to the DCP-1 input. Also, whatever DCP source connected to the DCP-1 input will be routed to the DSU output when the DSU is powered down or if it fails Power-Up BITE tests.

If the installation will use overlay then the OVRLY_PRI program pin (J2-44) must be set to the appropriate state (ground = DCP-1, open = DCP-2) to assign which DCP input is used as the overlay image.

UDI Display State
(non-error conditions)

CONFIGURATION:
 VIDEO INPUTS: TAWS TERRAIN and DCP 1
 OVERLAY? YES
 OVERLAY PRIORITY: DCP 1
 OPERATOR INPUTS USED:
 TERR_IN
 PROGRAM PIN STATES:
 UD12_IN_EN = OPEN
 OVRLY_IN_EN = OPEN
 DSUOUT_IN_EN = OPEN
 OVRLY_ACT = GROUNDED
 OVRLY_PRI = GROUNDED
 IND300_EN(G) = display dependent

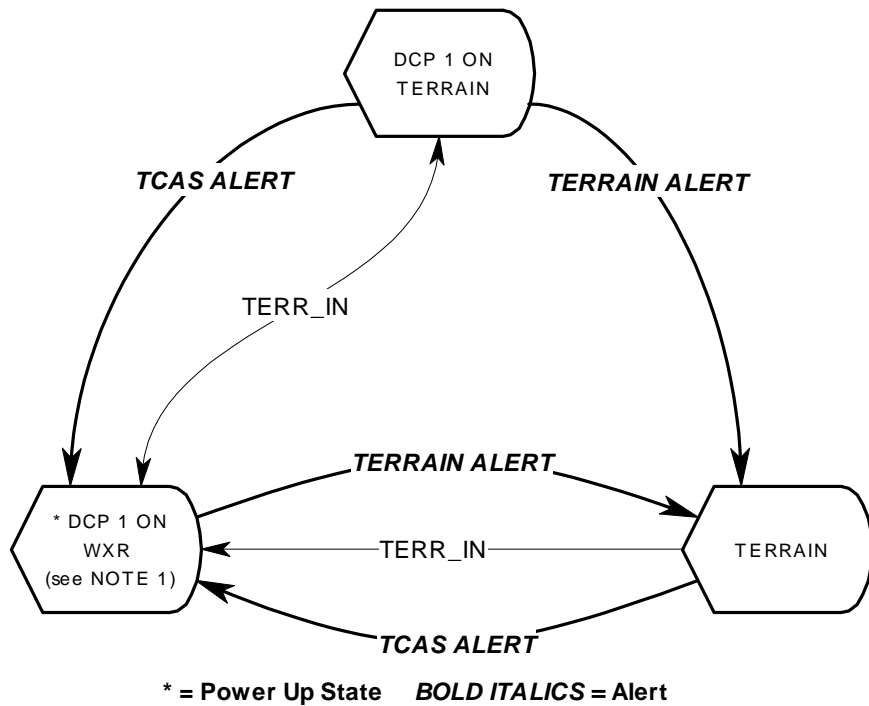

NOTE 1: DCP 1 video must be disabled at the source to display WXR only

Figure 7 DCP Display State: One DCP Source, Overlay Always Enabled

The flexibility of the DSU provides a way to install a system with two DCP sources and a TAWS without the need of switches for the DCP1/2_IN and OVRLAY_IN Operator Inputs. For example, if the OVRLY_ACT program pin (J2-43) is grounded, OVRLY_IN_EN program pin (J2-41) is left open, and the OVRLY_PRI program pin is left open then the DSU will use DCP-2 as the overlay image with terrain data or DCP-1 as the base image as selected using the TERR_IN Operator Input. This configuration works because the default state for the DCP1/2_IN Operator Input is DCP-1. This cannot change since this configuration does not have a switch for the DCP1/2_IN input.

The TERR_STATUS (J2-32), DCP1_STATUS (J2-33), and DCP2_STATUS (J2-34) discrete outputs may be used to monitor the state of DSU output to the DCP display. The table below shows how the outputs reflect the data combinations being sent by the DSU.

Table 4 - Data Displayed vs. Status Output			
Data Displayed by DSU	Status Output Active		
	TERR_STATUS	UDI1_STATUS	UDI2_STATUS
DCP-1 Only		Active	
DCP-2 Only			Active
Terrain Only	Active		
DCP-1 with DCP-2 as overlay		Active	Active
DCP-2 with DCP-1 as overlay		Active	Active
Terrain with DCP-1 as overlay	Active	Active	
Terrain with DCP-2 as overlay	Active		Active

The DISPLAY_INVALID (J1-7) discrete output may be used to monitor the health of the DSU.

6 **INSTALLATION TESTS**

The following tests must be performed to ensure the installation in the airplane is operating properly.

6.1 **Basic DSU Operational Tests**

6.1.1 WXR Indicator Calibration

Ensure that the Weather Radar Indicator has been properly calibrated per the appropriate Collins calibration procedure. It is very important to maintain calibration of the WXR indicator to ensure proper alignment of the images from the various sources.

6.1.2 TAWS Connection Test

Press the TAWS self-test button or run a TAWS test script to ensure the TAWS is properly connected to the DSU. If properly connected, a test pattern will be shown on the display and the range information will be consistent with the range selected on the display.

6.1.3 Terrain / Weather Radar Switching Test

Press the Terrain switch and ensure that the displayed image switches between WXR and Terrain data. In the Weather Radar mode “WXR” is shown in the lower left corner of the display. In the terrain mode “TERR” is shown in the lower left corner of the display.

6.1.4 WXR Range Rings and TERR Range Rings Alignment Test

Examine the alignment of the range rings by switching between WXR and TERR modes. Observe the location of the outer range ring. If the range rings are aligned there should be no noticeable difference in the location of the range rings. There are no adjustments in the DSU for this test. Proper WXR Indicator calibration should correct any mis-alignments.

6.1.5 Terrain ON Indicator Test

Switch between WXR and TERR modes. The “ON” indicator on the terrain switch must come on each time the display is in the TERR mode. The “ON” indicator must go off each time the display is in the WXR mode.

6.1.6 DCP Range Data Test

Put the display in the TERR mode. Set the range switch on the display to the lowest range. Verify that the display flashes the lowest range at least once before it becomes solid. Select the next highest range one at a time and verify that the number stops flashing after a few times and becomes solid. Verify that all ranges appropriate for the type of display being tested are available and are in the correct order. If the upper range appears incorrect, check the WD300_EN(G) pin for proper setting.

6.1.7 Display Size Test

With the display in the TERR mode, the range rings, the “TERR” text, and the range text must all be visible. If any appear truncated, then check the calibration of the WXR indicator for proper settings.

6.2 DCP-1 Input Tests (optional input)

6.2.1 DCP-1 Overlay Function Test

Set up WXR display to show a Terrain image. Press the OVERLAY switch. The overlaid image must be that of DCP-1.

6.2.2 DCP-1 Aircraft Origin Test

If the DCP-1 has an aircraft origin, verify that it is consistent with the WXR and TERR origin. If it is not, adjust the DCP-1 source or wiring.

6.2.3 Bypass Mode Test (remove DSU power)

Set up the DSU for normal operation with TERR enabled and remove power from the DSU. The DCP-1 image must appear on the WXR. Reconnect power to the DSU. It must return to normal operation.

6.2.4 TCAS Alert Test (pop up)

If TCAS is being used on DCP-1, switch the DSU to WXR mode and simulate a TCAS alert. The TCAS image must appear on the display. After two seconds, press the TERR switch. The TERR mode display must appear.

6.3 **DCP-2 Input Tests (optional input)**

6.3.1 DCP-2 Overlay Function Test

Set up display to show a Terrain image. Press the OVERLAY switch. The overlaid image must be that of DCP-2.

6.3.2 DCP-2 Aircraft Origin Test

If the DCP-2 has an aircraft origin, verify that it is consistent with the WXR and TERR origin. If it is not, adjust the DCP-2 source or wiring.

6.4 **DSU INOP Indicator Test (optional indicator)**

Reset DSU. The indicator must come on for two seconds then go off.

6.5 **DCP-1 Indicator Test (optional indicator)**

Verify that the indicator comes on when the DCP-1 image is present on the display.

6.6 **DCP-2 Indicator Test (optional indicator)**

Verify that the indicator comes on when the DCP-2 image is present on the display.

7 SPECIFICATIONS

7.1 DSU Characteristics

Model Number:	6001-1-4
Certification:	TSO-C105 JTSO-C105 (expected one month after TSO-C105 authorization)
Confirms to RTCA Spec:	RTCA DO-160D, refer to paragraph 7.2
Software Certification:	Software has been tested and documented per RTCA paper DO-178B for Category C equipment.
Size:	Refer to Figure 0
Mounting:	Flange mounting via DSU through holes and number six mounting hardware.
Weight:	6001-1-4: 2.5 lbs nominal
Operating Temperature:	-55 to +70 degrees C
Storage Temperature:	-55 to +85 degrees C
Vibration:	RTCA DO-160D, refer to paragraph 7.2
Operating Altitude:	RTCA DO-160D, refer to paragraph 7.2
Input Voltage:	22.0 Vdc - 29.5 Vdc. Voltage below 20.5 or above 32.2 is considered abnormal and unit may not operate per specifications.
Input Current:	1.2 amps nominal, circuit breaker must be rated for 2.0 amps.
ARINC Interfaces:	ARINC 429, 453
Self Test:	No operator initiated self test provided. Power up BIT checks ROM Checksum, RAM, Processor communications and watchdog timer. Continuous BIT checks TAWS 453 bus and display range bit data.
Reliability:	MTBF is predicted to be 70,000 hours

7.2

Operational Environment

Test	DO160D Section	Category	Comments
Temperature (High/Low)	4.0	F2	Operating : -55 degrees C to +70 degrees C Ground Survival: -55 degrees C to +85 degrees C
In-Flight Loss of Cooling	4.5.4	-	no cooling required
Altitude	4.6.1	F2	55,000 feet
Decompression	4.6.2	A2	55,000 feet
Overpressure	4.6.3	A2	-15,000 feet
Temperature Variation	5.0	B	5 degrees C / min
Humidity	6.0	A	48 Hours @ 95% RH 38 – 65 degrees C, non-operating
Shock-Operating	7.0	B	normal: 6g, 11 msec sawtooth low freq.: 6g, 20 msec sawtooth
Shock-Crash Safety	7.0	B	20g 11 msec sawtooth 20g sustained
Vibration	8.0	SL,RCC1	sinusoidal: 0.1"p-p @ 5-15Hz; 0.01"p-p @ 15-55Hz, decaying to 0.0001"p-p @ 500Hz random: 5.83 grms
Explosion Proofness	9.0	X	No test required
Waterproofness	10.0	X	No test required
Fluids Susceptibility	11.0	X	No test required
Sand and Dust	12.0	X	No test required
Fungus Resistance	13.0	F (cert.)	No test (non-nutrient material certification)
Salt Spray	14.0	X	No test required
Magnetic Effect	15.0	Z	less than 0.3m

Test	DO160D Section	Category	Comments
Power Input	16.0	A	Normal: 22.0 – 30.3 VDC Abnormal (5 minutes): 20.5 – 32.2 VDC Emergency (30 minutes): 18 VDC Interrupt for 200msec Normal Surge (30msec): 15 - 40VDC Abnormal Surge: 100msec @ 46.3VDC 1sec @ 37.8VDC
Voltage Spike	17.0	A	600VDC, 10µsec, 50Ω source impedance
AF Conducted Susceptibility (Power Lines)	18.0	Z	0.20 Vrms 10-200 Hz 0.56 Vrms, 200 – 1000 Hz 1.40 Vrms, 1000 – 15,000 Hz 0.20 down to .001 Vrms, 15 kHz – 150 kHz.
Induced Signal Susceptibility	19.0	Z	Magnetic, unit: 20 Arms a 400Hz Magnetic, cables: 30 A-m @400Hz down to 0.8 A-m @ 15KHz Electric, cables: 1800 V-m, 380 – 420 Hz Induced spikes: 600 V p-p, 2-10µsec rate, 3 meters
RF Conducted Susceptibility	20.0	R	10 kHz – 500 kHz: 0.6mA – 30.0 mA 500 kHz – 400 MHz: 30.0 mA
RF Radiated Susceptibility	20.0	R	20 V/m, 0.1 – 0.4 GHz, SW & CW 150 V/m, 0.4 – 8 GHz, Pulse
RF Conducted Emissions	21.0	M	Power: 53 – 20 dBµA @ 0.15 – 2 MHz, 20 dBµA @ >2MHz Cables: 73 – 40 dBµA @ 0.15-2MHz, 40 dBµA @ > 2MHz
RF Radiated Emissions	21.0	M	Complex curves with notches (see DO160D)

Test	DO160D Section	Category	Comments
Lightning Transient Susceptibility	22.0	A3E3	Pin: 600V/24A, 300V/60A Cable: 300V/600A, 600V/120A
Lightning Direct Effects	23.0	X	No test required
Icing Test	24.0	X	No test required
Electrostatic Discharge Test	25.0	A	15,000 volts